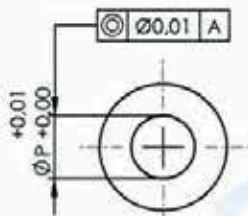
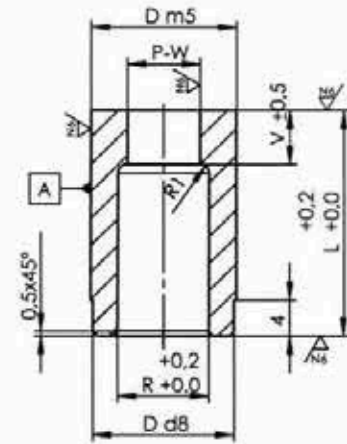
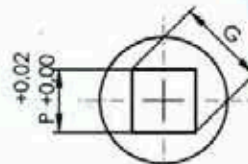
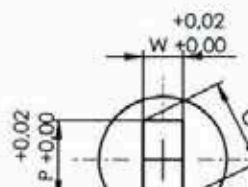
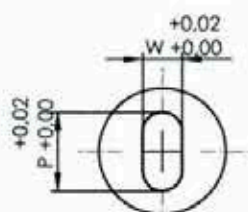

**MATRIZ LISA**
**REF. 863L**

**863L1**

**863L2**

**863L3**

**863L4**

D	V	P-W Mini.	P-G Maxi.	R	L	
8	5	2	3	4	25	32
10	5	2	5	6	25	32
13	5	2	7	8	25	32
16	5	2,5	8,5	9,5	25	32
20	5	3,2	11	12	25	32
22	6	4	14	15	25	32
25	6	4,8	16,5	17,5	25	32
32	6	5,5	20	21	25	32
38	8	6,4	26	27	25	32
40	8	6,4	26	27	25	32
45	8	8	35	36	25	32
50	8	9	40	41	25	32
56	8	10	45	46	25	32
63	8	11	50	51	25	32

**MATERIAL:** 1.2379 y HSS  
**TRATAMIENTO:** T. y R. 60÷63 HRc.

De no especificar material se suministrará 1.2379

**COMO PEDIR:**

Código pieza.  
 Diámetro cuerpo.  
 Dimensiones forma.  
 Clase antigiro (si se desea antigiro).  
 Grados antigiro.

**EJEMPLOS DE PEDIDO:**

863L1 D-13 P-6 L-25  
 863L1 D-13 P-6 L-25-S-0°  
 863L2 D-13 P-6 L-32-S-90°  
 863L3 D-13 P-8 W-5 L-25-P-0°  
 863L4 D-13 P-8 W-5 L-32-ES-45°

**ANTIQUIROS:**

0°, 90°, 180°, 270° ó X-º (a especificar) ver página de antigiros.